



Billi Quadra Plus 9 with XL Levered Dispenser & Gooseneck Mixer

Enjoy all the space saving benefits of Billi's water cooled boiling and chilled Quadra systems PLUS a separate sink mixer to ensure safety and convenience for all users.

Requiring only cold feed mains supply, the Quadra Plus mixes it's own hot water without the need for any additional under-bench space requirements or boosters. All Quadra Plus boiling & chilled models are Global Greentag certified to a Gold standard and require no joinery ventilation.

Supplied standard with a DDA compliant XL levered drinking water dispenser and 6 star rated mixer tap, the solution is both functional and appealing.

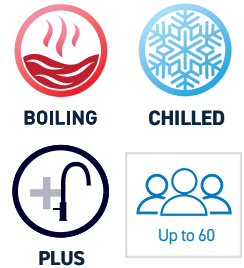

Features



XL Levered Dispenser

Gooseneck Mixer

Quadra Plus 9 Under-Bench Unit



Finishes

Standard Finishes

Special Order Finishes



Add the relevant Finish Code to the Product code to complete your specification, eg. 904065LGCH-LF

Accessories

992800 - 70mm Riser & Font

992820 - 70mm Riser



992803 - 120mm Riser & Font

992830 - 120mm Riser



990720 - Tubing Extension Kit for X series dual temp dispensers 2mtrs

Product Specifications

Water Type	BCHA
Dispenser	L - XL Levered Dispenser
Mixer Tapware	G - Gooseneck Mixer
Product Code	904065LG
Warranty	3 years manufacturers warranty
Under-Bench Dimensions	315mm(W) x 340mm (H) x 465mm (D)
Boiling Output	Up to 180 cups per hour
Chilled Output	Up to 175 cups per hour
Sparkling Output	N/A
50°C Hot Water Output	Up to 60L per hour
Min / Max Dispenser Temp	6°C / 99°C
Power Plug	10 amp
Power Rating	2300W, 220-240V ~ 50-60Hz
Water Pressure	Min. 250kPa
Ecolabel	Global GreenTag LCARate GOLD
EPD	✓
Greenstar Contribution	Up to 16 Points
Watermark License	WM-021525 (unit), WM-25901 (tap)
Lead Free	✓
Section J7.7 (NCC)	✓
WELS	6 Star - 0133
WELL	Cornerstone Membership
Management Systems	Every Billi drinking water appliance is manufactured under the strictest standards and is certified in accordance with: ISO9001 for QMS (FS 790754), ISO14001 for EMS (EMS 801468) and ISO45001 for OSHS (OHS 801469).
Food Handling	HACCP License No. PE-872-WAT-1-02
Filtration	994051 - 5.0 Micron supplied standard

Scan the QR code access our Revit families on

bimstore

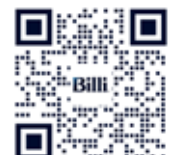

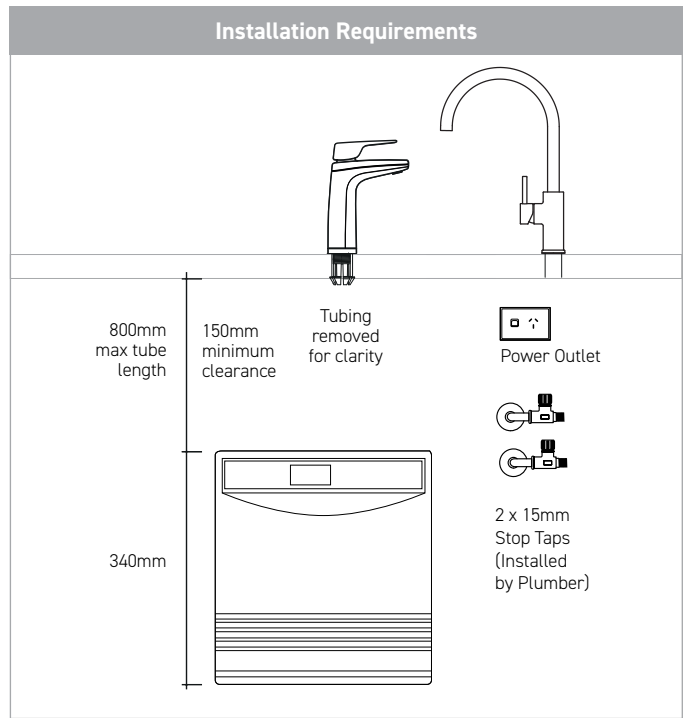
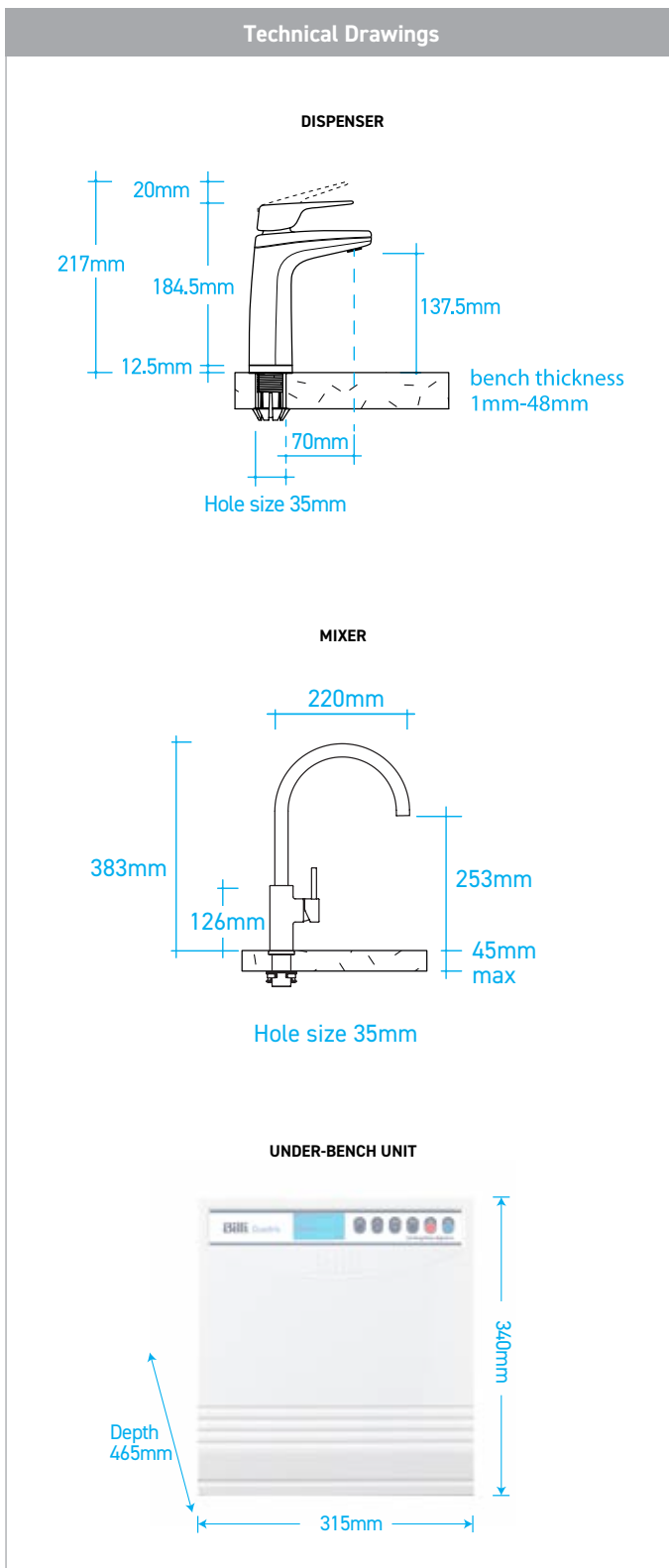

Installation Notes

Electrical	A standard 10 amp power outlet is required, located no further than 1000mm from the underbench unit. The system is supplied with a 1 metre flex cord and plug.
Water	Two (2) Cold 1/2" BSP (15mm) stop-taps with a male thread should be installed in an easily accessible position. Water supply must be microbiologically safe to drink, with a minimum dynamic water pressure of 250kPa and a maximum of 1000kPa.
Pressure Valve	Integrated 500kPa pressure limiting and dual check valve is pre-installed to the unit inlet.
Stone Benches	Billi has a no-cut policy regarding all stone benches in compliance with regulations. The safety of our team and customers remains Billi's top priority.
Ventilation	No joinery ventilation or accessories are required for this Billi product (water cooled technology).

Filtration - Most Recommended Replacement Filters

Billi range of premium filters utilize BWT's unique FibronX® technology, providing superior taste, water quality, filter life longevity and peace of mind when it comes to hygiene.

<p>994051 - (5.0 micron)</p> <p>Supplied standard. Commercial & high volume sites.</p>	<p>994052 - (0.2 micron)</p> <p>Fine filtration. Residential or Critical Care sites.</p>
---	---

*Drawings are for guidance during Specification, refer to Installation requirements for final install. All efforts are made to ensure Compliance & Certifications claims are current, however this is subject to change without notice. Billi assumes no liability or responsibility for out of date information



Technical support

Book a service call

Filtration & service

Warranty registration

Please scan the QR code for all support information.

Billi Australia Pty Ltd
P 1800 812 321
W www.billi.com.au

Billi New Zealand Ltd
P 0800 636 0 636
W www.billi.co.nz

