



Billi Quadra 4100 with XT Motion Dispenser

The Quadra Boiling and Chilled range is a commercial drinking water solution that is water cooled, so requires no joinery venting. The drawcard for the entire Quadra range is the use of innovative energy reclaim technology which enables space savings, energy efficiency and completely eliminates exhaust heat transfer. All Quadra boiling and chilled products are Global Greentag certified to a Gold standard.

The XT Motion dispenser delivers boiling, and chilled filtered water through an integrated dual-control interface that supports both touch and touch-free activation. The system allows users to dispense water with precision and safety using motion control, while enhancing hygiene and usability in high-use environments.



BOILING



CHILLED



Features



AUSTRALIAN
DESIGNED
& MADE



WATER
COOLED
TECHNOLOGY



HEAT
EXCHANGE
TECHNOLOGY



VENT-FREE
INSTALLATION



ENERGY
EFFICIENT



ECOLABEL
CERTIFIED

XT Motion
Dispenser



Quadra 4100
Under-Bench Unit



Finishes

Standard Finishes



CH -
Chrome



BR -
Brushed



MB -
Matte Black

Add the relevant Finish Code to the Product code to complete your specification eg 904100MCH-LF

Accessories

990720 - Tubing Extension Kit for X series dual temp dispensers 2mtrs

Product Specifications

Water Type	BC
Dispenser	M- XT Motion Dispenser
Mixer Tapware	N/A
Product Code	904100M
Warranty	3 years manufacturers warranty
Under-Bench Dimensions	315mm(W) x 340mm (H) x 465mm (D)
Boiling Output	Up to 250 cups per hour
Chilled Output	Up to 175 cups per hour
Sparkling Output	N/A
50°C Hot Water Output	N/A
Min / Max Dispenser Temp	6°C / 99°C
Power Plug	15 amp
Power Rating	3400W, 220-240V ~ 50-60Hz
Water Pressure	Min. 250kPa
Ecolabel	Global GreenTag LCARate GOLD
EPD	✓
Greenstar Contribution	Up to 16 Points
Watermark License	WM-021525
Lead Free	✓
Section J7.7 (NCC)	✓
WELS	N/A
WELL	Cornerstone Membership
Management Systems	Every Billi drinking water appliance is manufactured under the strictest standards and is certified in accordance with: ISO9001 for QMS (FS 790754), ISO14001 for EMS (EMS 801468) and ISO45001 for OSHS (OHS 801469).
Food Handling	HACCP License No. PE-138-BIL-R1-03
Filtration	994051 - 5.0 Micron supplied standard

Scan the QR code access
our Revit families on
bimstore

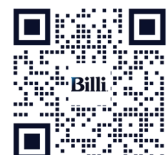

Technical Drawings

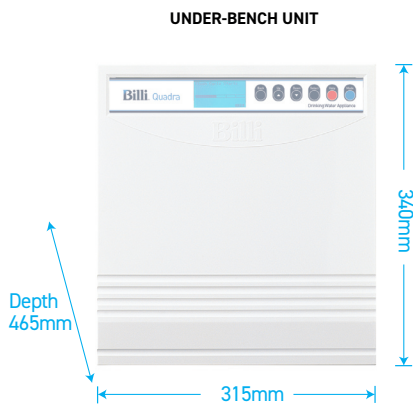
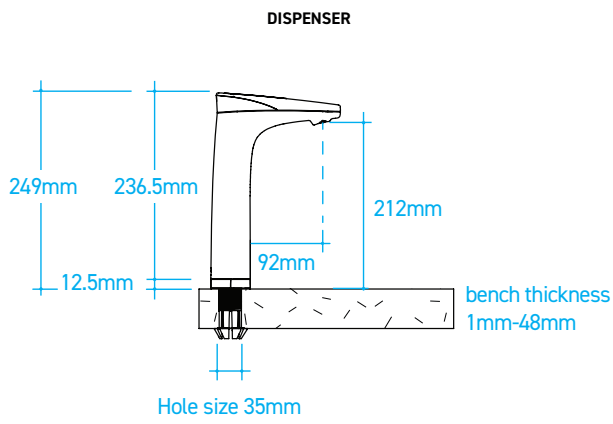

* Drawings are for guidance during Specification, refer to Installation requirements for final install. All efforts are made to ensure Compliance & Certifications claims are current, however this is subject to change without notice. Billi assumes no liability or responsibility for out of date information.

Installation Requirements

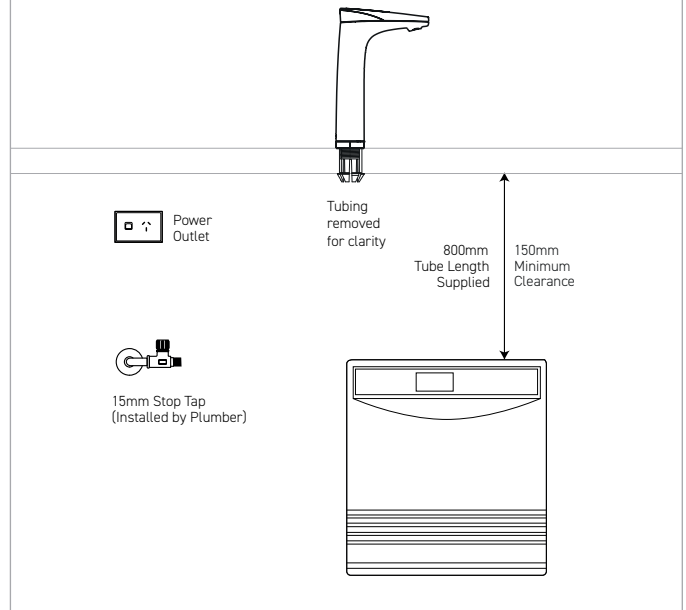

Installation Notes

- Electrical** A standard 15 amp power outlet is required, located no further than 1000mm from the underbench unit. The system is supplied with a 1 metre flex cord and plug.
- Water** A single 1/2" BSP (15mm) stop-tap with a male thread should be installed in an easily accessible position. Water supply must be microbiologically safe to drink, with a minimum dynamic water pressure of 250kPa and a maximum of 1000kPa.
- Pressure Valve** Integrated 500kPa pressure limiting and dual check valve is pre-installed to the unit inlet.
- Stone Benches** Billi has a no-cut policy regarding all stone benches in compliance with regulations. The safety of our team and customers remains Billi's top priority.
- Ventilation** No joinery ventilation or accessories are required for this Billi product (water cooled technology).

Filtration - Most Recommended Replacement Filters

Billi range of premium filters utilize BWT's unique FibronX® technology, providing superior taste, water quality, filter life longevity and peace of mind when it comes to hygiene.

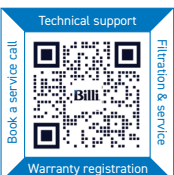

Please scan the QR code for all support information.

Billi Australia Pty Ltd
P 1800 812 321
W www.billi.com.au

Billi New Zealand Ltd
P 0800 636 0 636
W www.billi.co.nz

